

Outdoor Sofa with Chaise Longue

Soffa med schäslong

Sofa med sjeselong

Ulkosohva

Sofa mit Recamiere

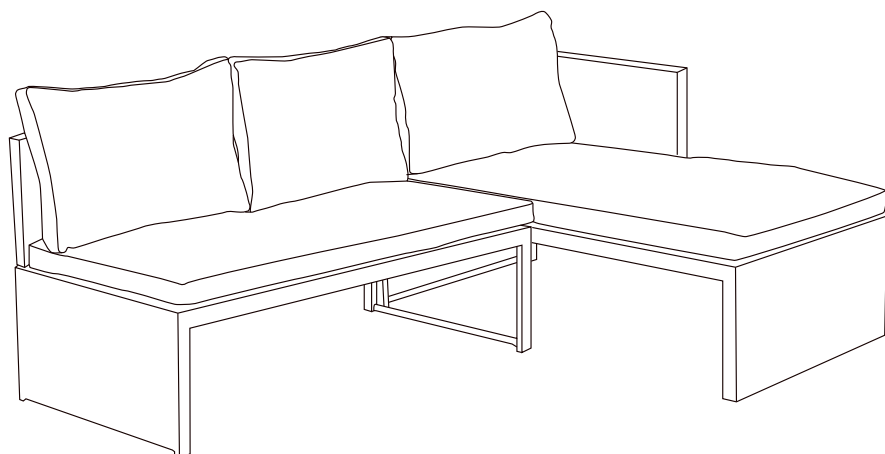

Art.no

31-9240

Model

710.032.013

Ver. 20170510

clas ohlson

English

Svenska

Norsk

Suomi

Deutsch

Outdoor Sofa with Chaise Longue

Art.no 31-9240 Model 710.032.013

Please read the entire instruction manual before using the product and then save it for future reference. We reserve the right for any errors in text or images and any necessary changes made to technical data. In the event of technical problems or other queries, please contact our Customer Services (see address details on the back).

Assembly



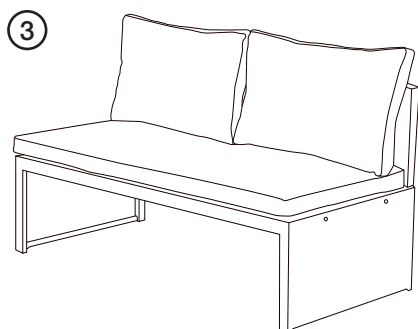
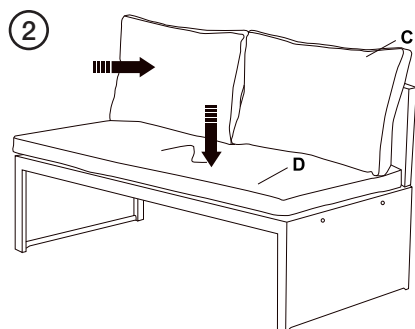
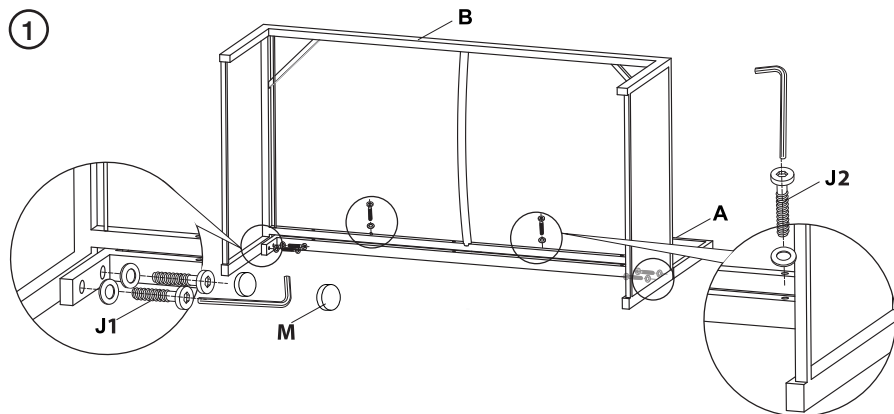
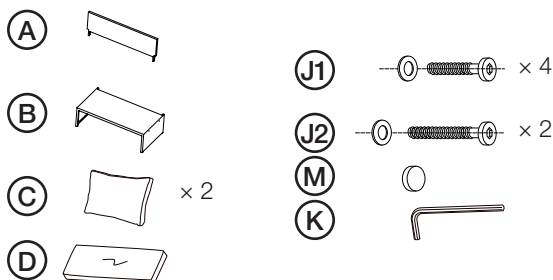

Sofa

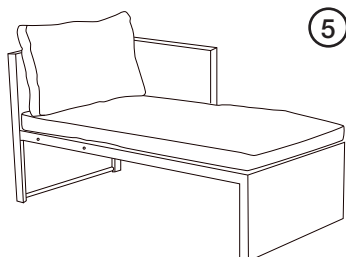
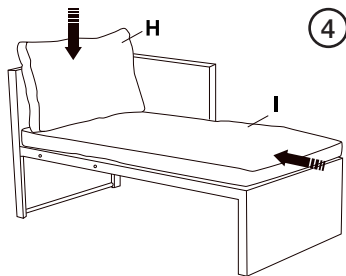
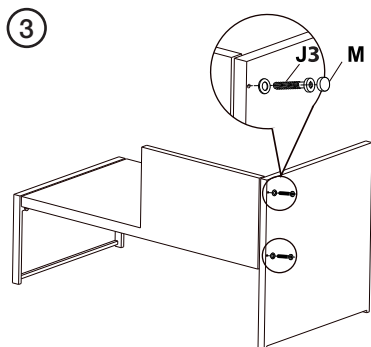
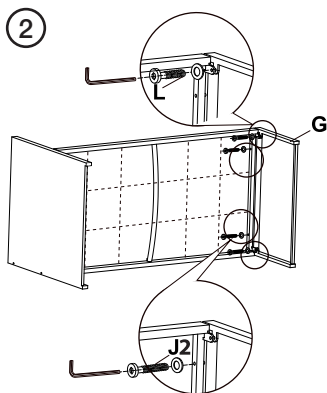
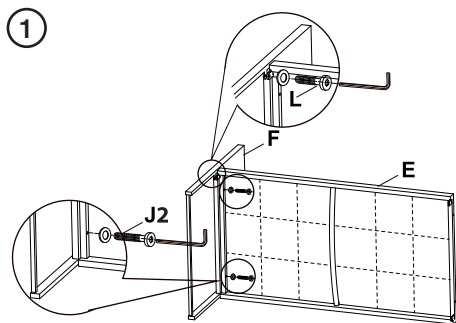
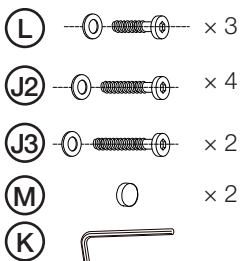
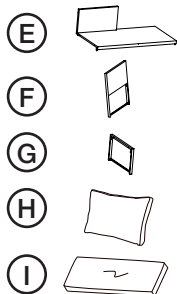

Chaise longue



Joining the furniture together

- (K)** 
- (N)**  × 2
- (O)**  × 2
- (P)** 

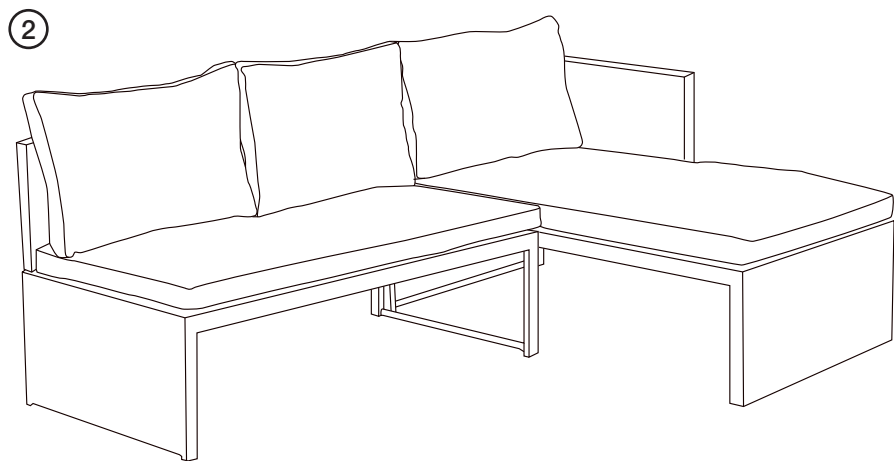
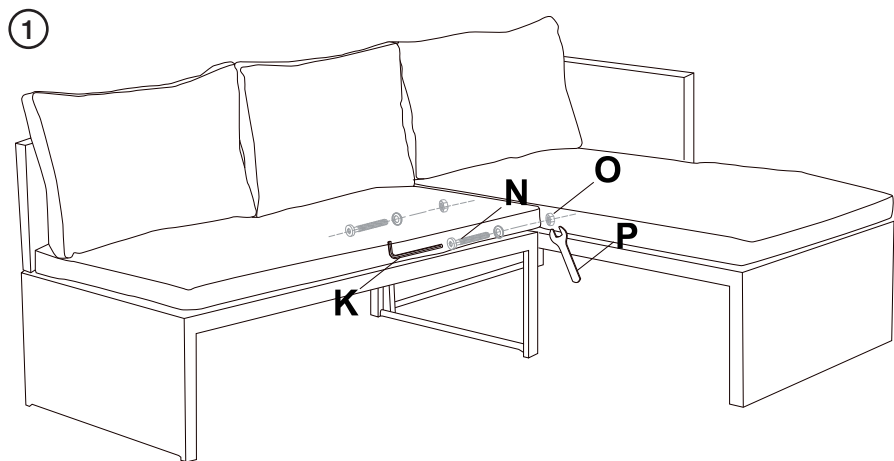

Care and maintenance

- The furniture can be wiped clean using a damp cloth and mild detergent. Never use bleach or abrasive cleaning agents.
- The furniture should be stored in a cool, dry location during the winter. Covering the furniture with a sheet or tarpaulin during storage is also advisable.
- Regularly check that all screws are securely tightened.

Responsible disposal

This symbol indicates that this product should not be disposed of with general household waste. This applies throughout the entire EU. In order to prevent any harm to the environment or health hazards caused by incorrect waste disposal, the product must be handed in for recycling so that the material can be disposed of in a responsible manner.

When recycling your product, take it to your local collection facility or contact the place of purchase. They will ensure that the product is disposed of in an environmentally sound manner.



Specifications

Size W x D x H 186 x 123 x 66 cm

Soffa med schäslong

Art.nr 31-9240 Modell 710.032.013

Läs igenom hela bruksanvisningen före användning och spara den sedan för framtida bruk. Vi reserverar oss för ev. text- och bildfel samt ändringar av tekniska data. Vid tekniska problem eller andra frågor, kontakta vår kundtjänst (se adressuppgifter på baksidan).

Montering



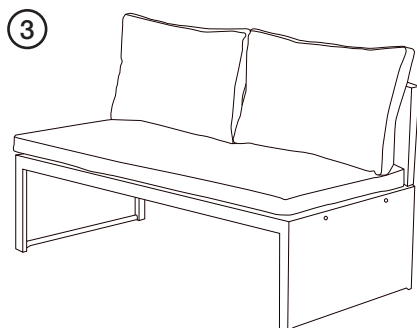
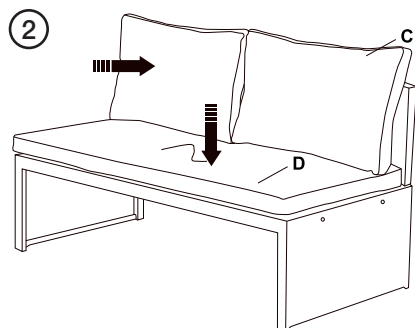
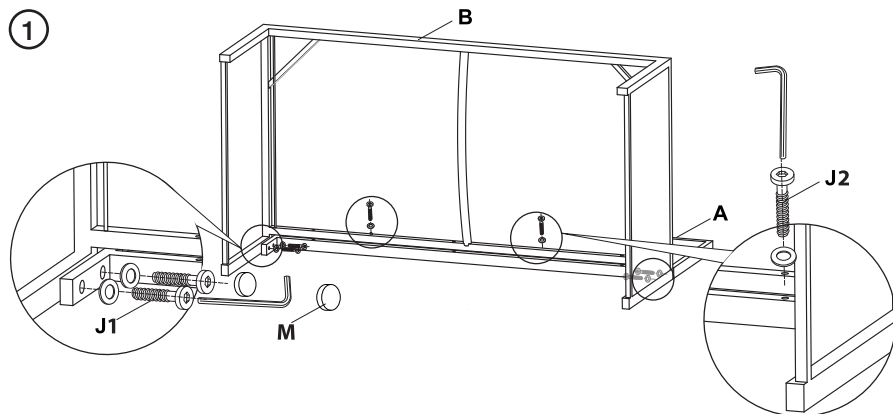
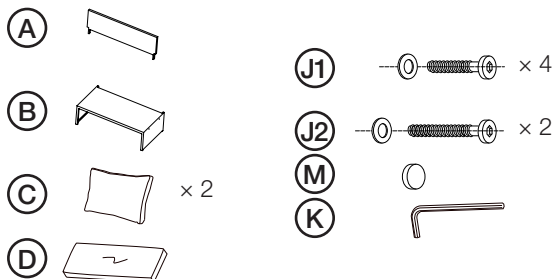

Soffa

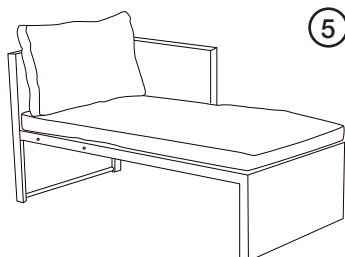
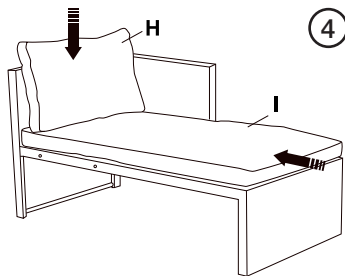
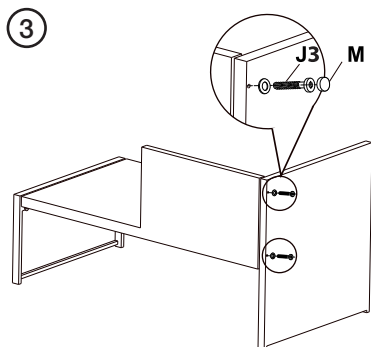
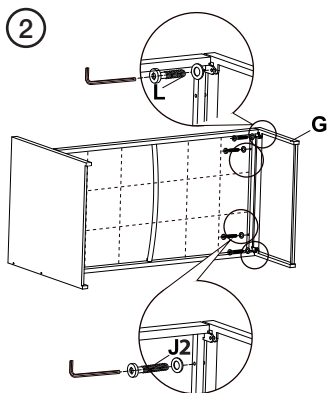
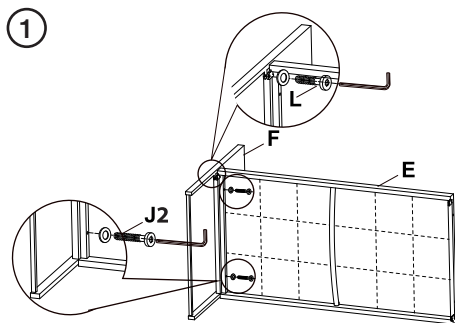
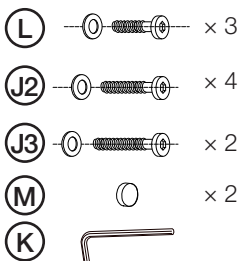
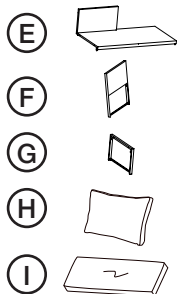

Schäslong



Sätt ihop soffan och schäslongen

- (K)** 
- (N)**  × 2
- (O)**  × 2
- (P)** 

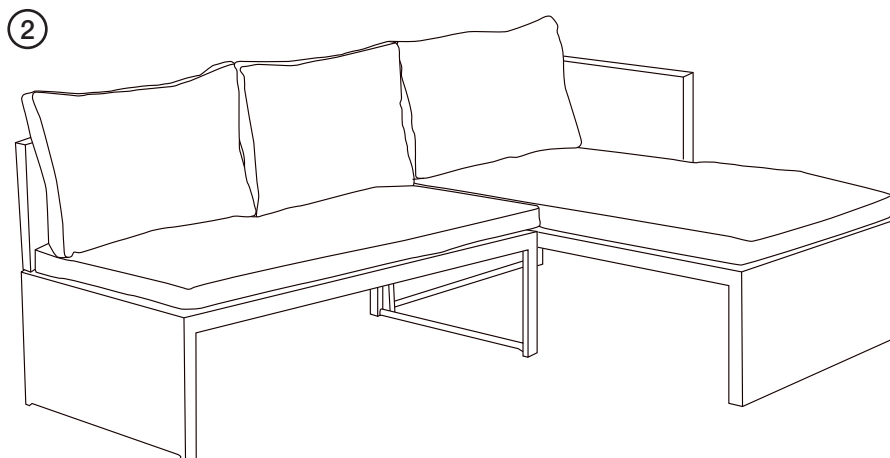
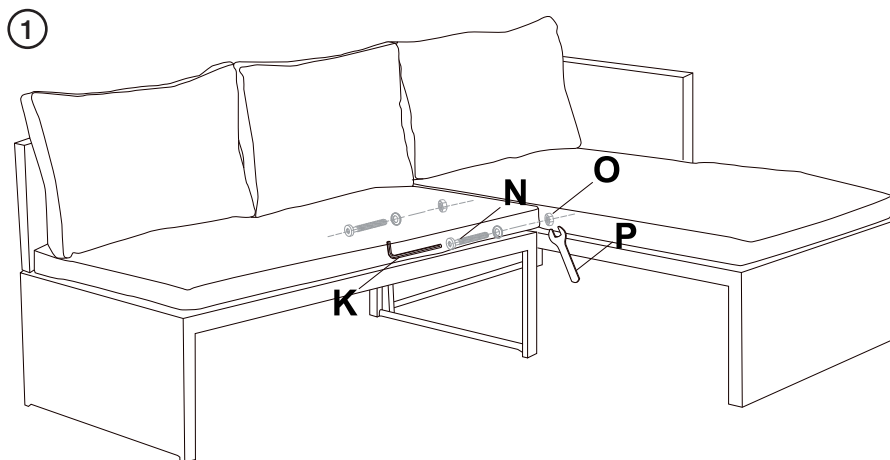

Skötsel och underhåll

- Använd en fuktig trasa och ett mildt rengöringsmedel när du torkar av möblerna. Använd aldrig blekmedel eller slipande rengöringsmedel.
- Under exempelvis vintern, förvara möblerna i ett torrt och svalt utrymme. Gärna övertäckta med en presenning.
- Kontrollera regelbundet att alla skruvar är ordentligt fastskruvade.

Avfallshantering

Denna symbol innebär att produkten inte får kastas tillsammans med annat hushållsavfall. Detta gäller inom hela EU. För att förebygga eventuell skada på miljö och hälsa, orsakad av felaktig avfallshantering, ska produkten lämnas till återvinning så att materialet kan tas omhand på ett ansvarsfullt sätt. När du lämnar produkten till återvinning, använd dig av de returhanteringssystem som finns där du befinner dig eller kontakta inköpsstället. De kan se till att produkten tas om hand på ett för miljön tillfredställande sätt.



Specifikation

Mått B x D x H 186 x 123 x 66 cm

Sofa med sjeselong

Art.nr. 31-9240 Modell 710.032.013

Les brukerveiledningen grundig før produktet tas i bruk og ta vare på den for framtidig bruk. Vi reserverer oss mot ev. feil i tekst og bilde, samt forandringer av tekniske data. Ved tekniske problemer eller spørsmål, ta kontakt med vårt kundesenter. (Se opplysninger om kundesenteret i denne bruksanvisningen).

Montering



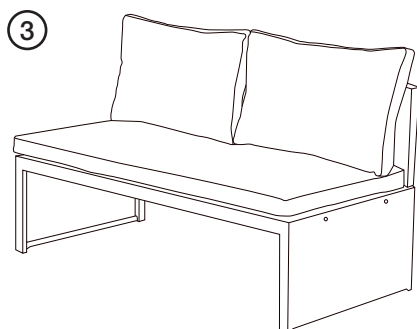
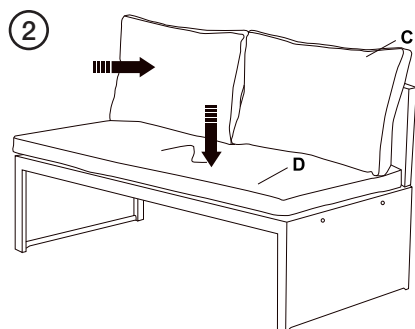
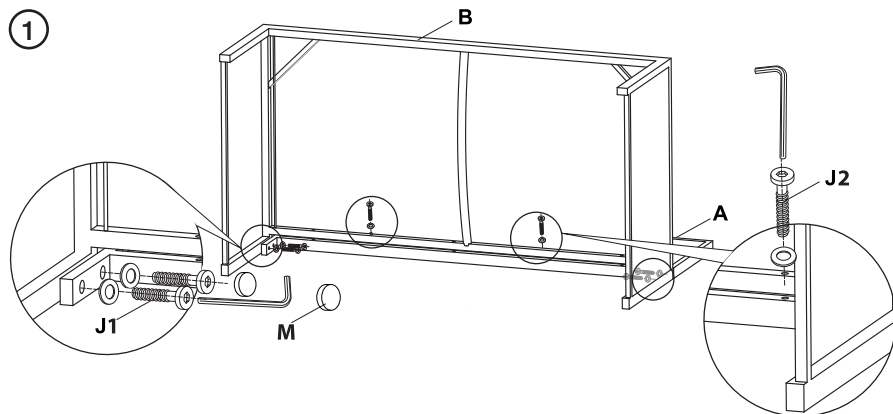
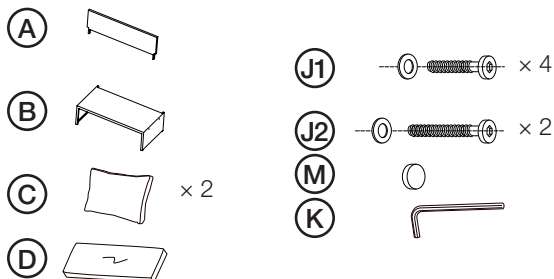

Sofa

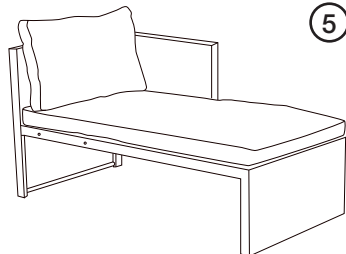
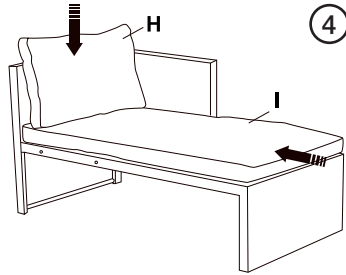
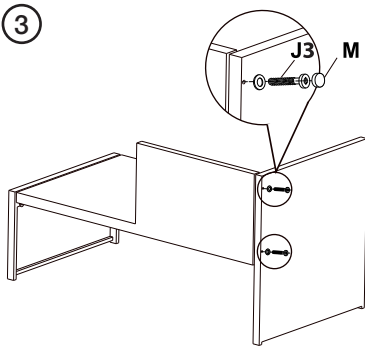
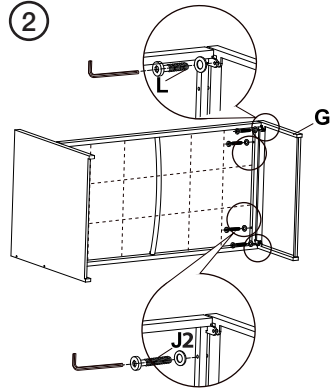
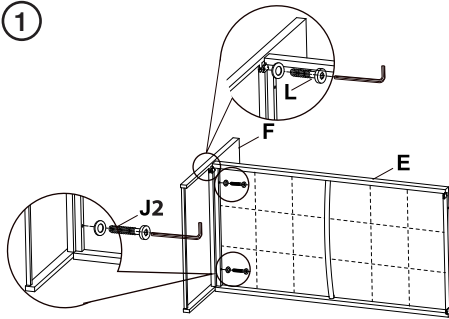
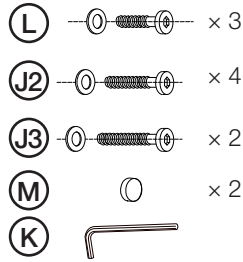
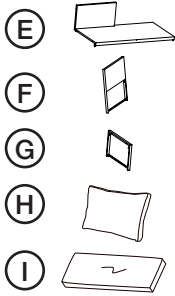

Sjeselong



Montering

- (K) 
- (N)  × 2
- (O)  × 2
- (P) 

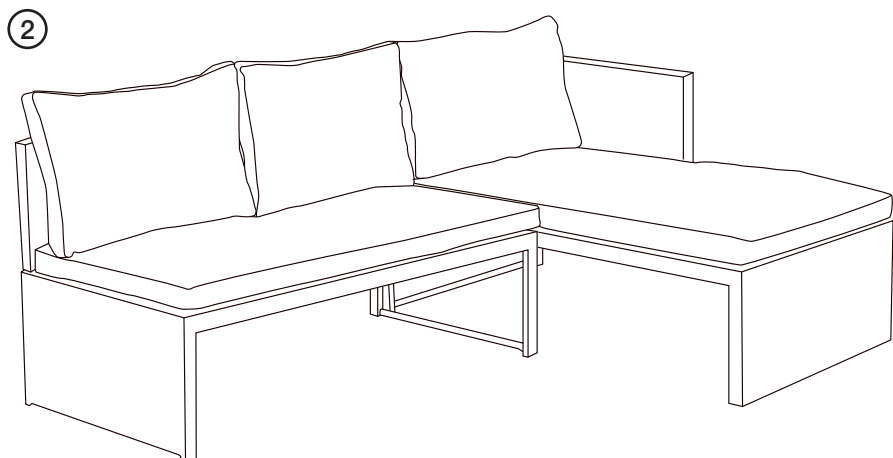
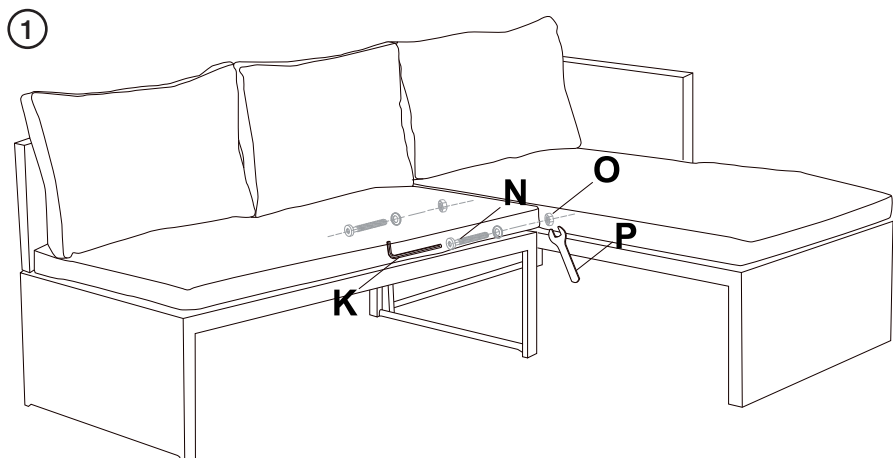

Stell og vedlikehold

- Bruk en lett fuktet klut og ev. et mildt rengjøringsmiddel til rengjøring av møblene. Bruk aldri blekende eller slipende rengjøringsmidler.
- Ved lagring f.eks. over vinteren bør møblene oppbevares tørt og kaldt. Dekk dem gjerne til med en presenning.
- Kontroller regelmessig at alle skruer er ordentlig festet.

Avfallshåndtering

Symbolet viser til at produktet ikke skal kastes sammen med husholdningsavfallet. Dette gjelder i hele EØS-området. For å forebygge eventuelle skader på helse og miljø som følge av feil håndtering av avfall, skal produktet leveres til gjenvinning, slik at materialet blir tatt hånd om på en ansvarsfull måte. Benytt miljøstasjonene som er der du befinner deg eller ta kontakt med forhandler. De vil ta hånd om produktet på en miljømessig tilfredsstillende måte.



Spesifikasjon

Mål B x D x H 186 x 123 x 66 cm

Ulkosohva

Tuotenumero 31-9240 Malli 710.032.013

Lue käyttöohje ennen tuotteen käyttöönottoa ja säilytä se tulevaa tarvetta varten. Pidätämme oikeuden teknisten tietojen muutoksiin. Emme vastaa mahdollisista teksti- tai kuvavirheistä. Jos tuotteeseen tulee teknisiä ongelmia, ota yhteys myymälään tai asiakaspalveluun (yhteystiedot käyttöohjeen lopussa).

Asennus



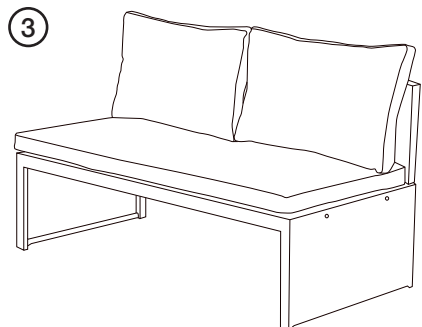
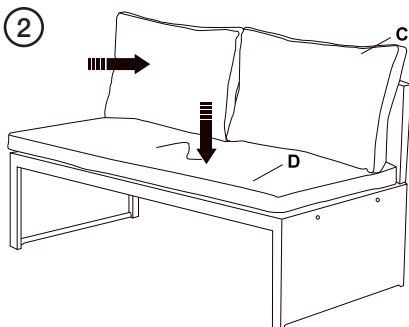
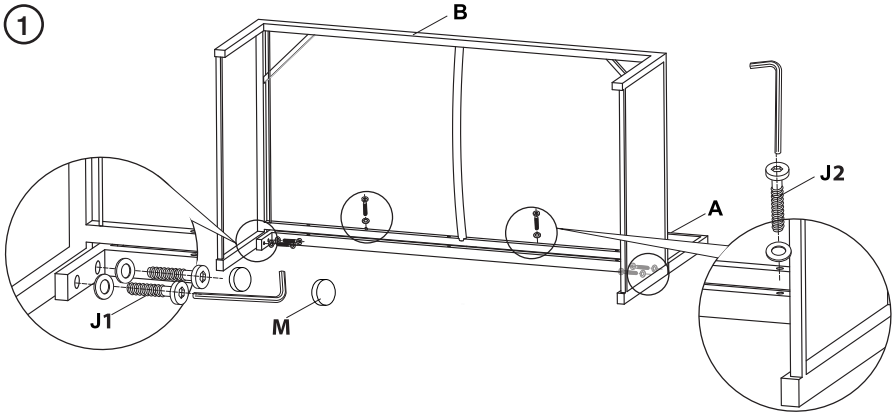
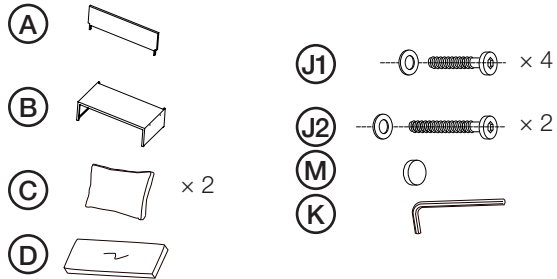

Sohva

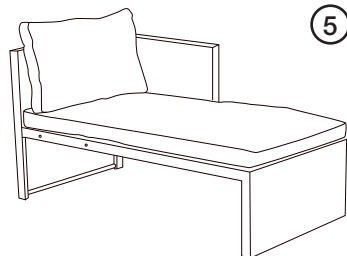
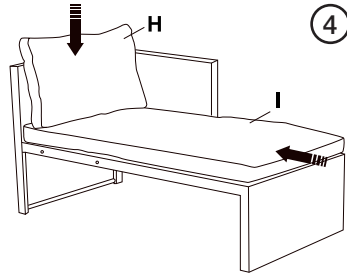
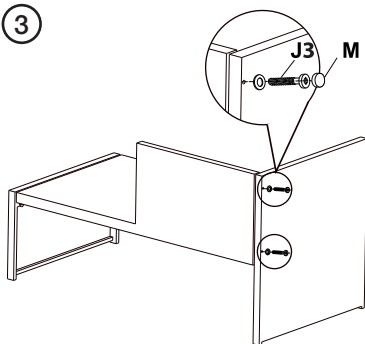
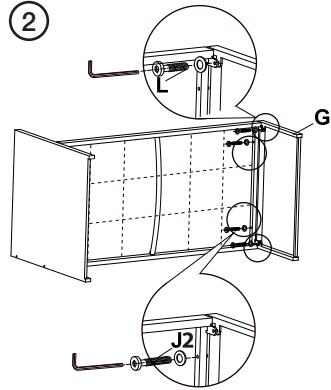
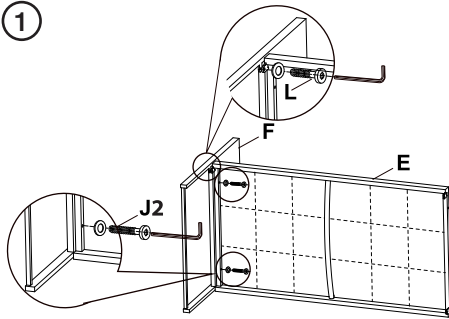
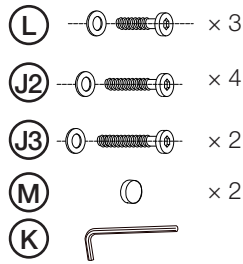
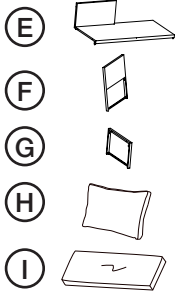

Divaani



Asennus yhteen

- (K)** 
- (N)**  × 2
- (O)**  × 2
- (P)** 

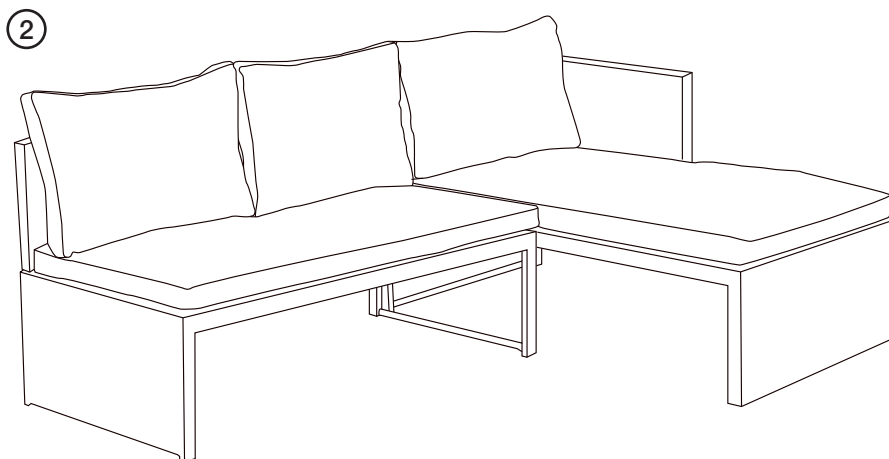
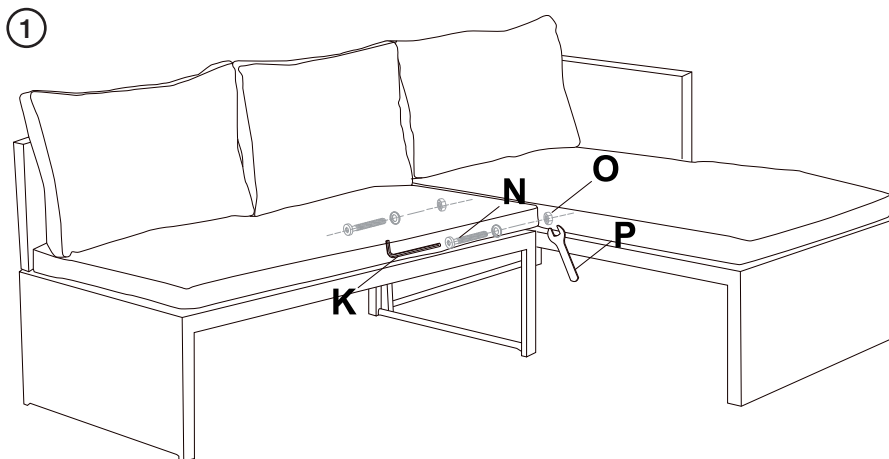

Huolto ja ylläpito

- Pyyhi kalusteet kostealla liinalla ja miedolla puhdistusaineella. Älä käytä valkaisuaineita tai hiovia puhdistusaineita.
- Säilytä kalusteita kuivassa ja viileässä tilassa esim. talvella. Kalusteet on hyvä peittää suojapeitteellä.
- Varmista säännöllisesti, että kaikki ruuvit ja mutterit ovat kireällä.

Kierrättäminen

Tämä kuvake tarkoittaa, että tuotetta ei saa hävittää kotitalousjätteen seassa. Tämä koskee koko EU-aluetta. Virheellisestä hävittämisestä johtuvien mahdollisten ympäristö- ja terveyshaittojen ehkäisemiseksi tuote tulee viedä kierrätettäväksi, jotta materiaali voidaan käsitellä vastuullisella tavalla. Kierrätä tuote käyttämällä paikallisia kierrätysjärjestelmiä tai ota yhteys ostopaikkaan. Ostopaikassa tuote kierrätetään vastuullisella tavalla.



Tekniset tiedot

Mitat L x S x K 186 x 123 x 66 cm

Sofa mit Recamiere

Art.Nr. 31-9240 Modell 710.032.013

Vor Inbetriebnahme die komplette Bedienungsanleitung durchlesen und aufbewahren. Irrtümer, Abweichungen und Änderungen behalten wir uns vor. Bei technischen Problemen oder anderen Fragen freut sich unser Kundenservice über eine Kontaktaufnahme (Kontakt siehe Rückseite).

Montage

Sofa

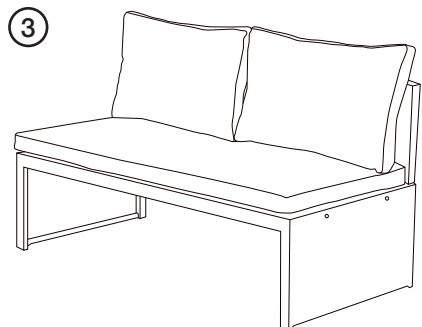
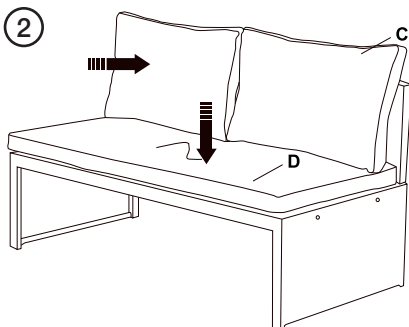
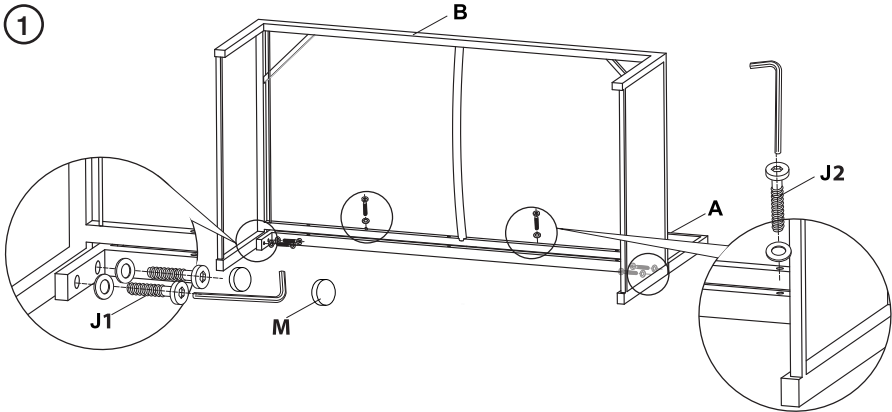
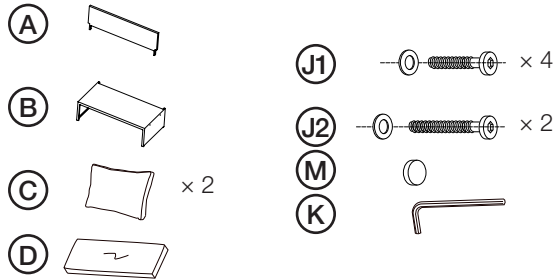

Récamière

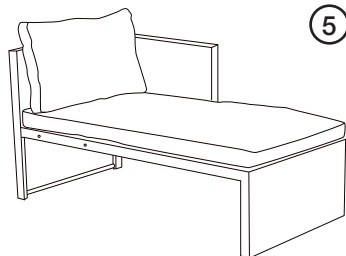
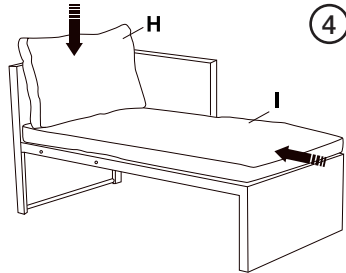
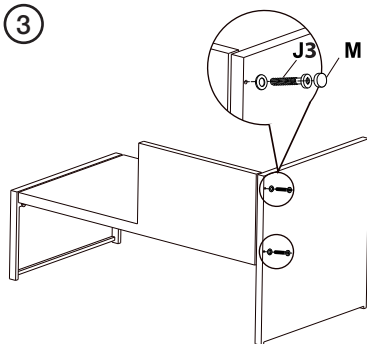
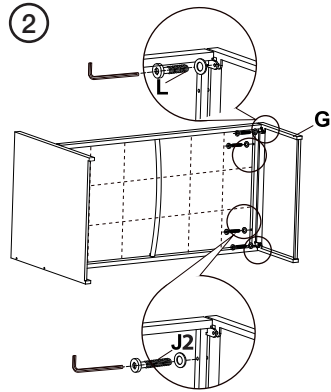
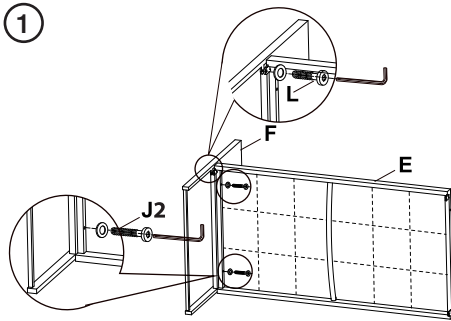
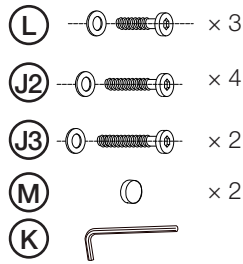
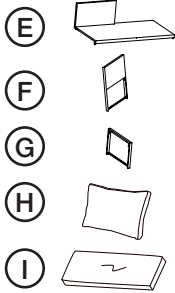

Montage

(K)



(N)



(O)



(P)



1

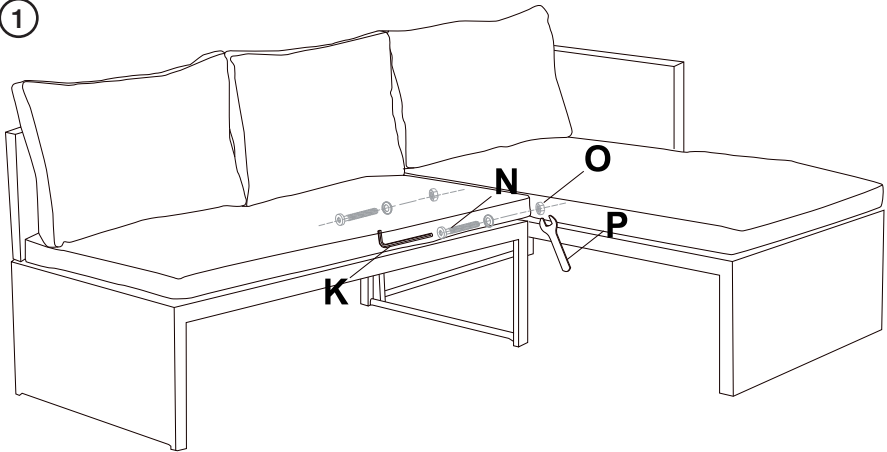

2

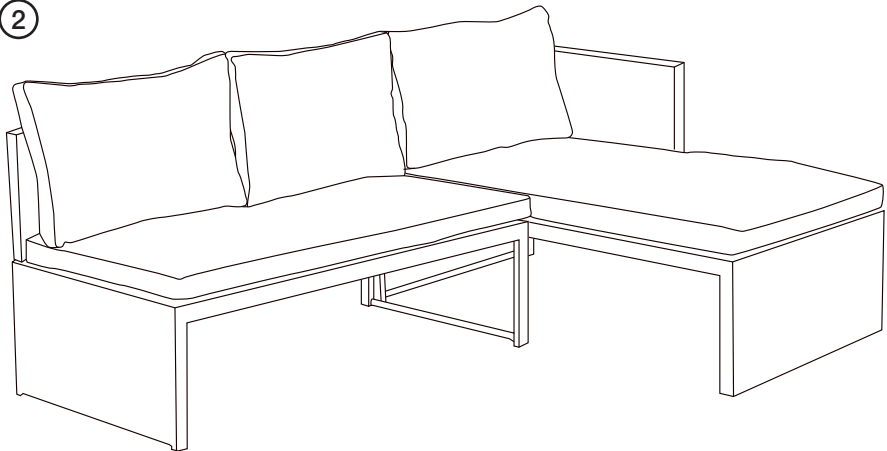

Pflege und Wartung

- Zum Abwischen der Möbel ein leicht befeuchtetes Tuch und ein mildes Reinigungsmittel verwenden. Zur Reinigung niemals Bleich-, oder Scheuermittel benutzen.
- Bei Nichtbenutzung in trockener, kühler Umgebung aufbewahren (z. B. im Winter). Am besten mit einer Plane überdeckt.
- Regelmäßig den festen Sitz aller Schrauben kontrollieren.

Hinweise zur Entsorgung

Dieses Symbol zeigt an, dass das Produkt nicht gemeinsam mit dem Haushaltsabfall entsorgt werden darf. Dies gilt in der gesamten EU. Um möglichen Schäden für die Umwelt und Gesundheit vorzubeugen, die durch fehlerhafte Abfallentsorgung verursacht werden, dieses Produkt zum verantwortlichen Recycling geben, um die nachhaltige Wiederverwertung von stofflichen Ressourcen zu fördern. Bei der Abgabe des Produktes bitte die vorhandenen Recycling- und Sammelstationen benutzen oder den Händler kontaktieren. Dieser kann das Produkt auf eine umweltfreundliche Weise recyceln.



Technische Daten

Maße B x T x H 186 x 123 x 66 cm

Sverige

Kundtjänst tel.: 0247/445 00
fax: 0247/445 09
e-post: kundservice@clasohlson.se

Internet www.clasohlson.se

Post Clas Ohlson AB, 793 85 INSJÖN

Norge

Kundesenter tlf.: 23 21 40 00
faks: 23 21 40 80
e-post: kundesenter@clasohlson.no

Internett www.clasohlson.no

Post Clas Ohlson AS, Postboks 485 Sentrum, 0105 OSLO

Suomi

Asiakaspalvelu puh.: 020 111 2222
sähköposti: asiakaspalvelu@clasohlson.fi

Internet www.clasohlson.fi

Osoite Clas Ohlson Oy, Kaivokatu 10 B, 00100 HELSINKI

Great Britain

Customer Service contact number: 020 8247 9300
e-mail: customerservice@clasohlson.co.uk

Internet www.clasohlson.co.uk

Postal 10 – 13 Market Place
Kingston Upon Thames
Surrey
KT1 1JZ

Deutschland

Kundenservice Hotline: 040 2999 78111
E-Mail: kundenservice@clasohlson.de

Homepage www.clasohlson.de

Postanschrift Clas Ohlson GmbH, Jungfernstieg 38,
20354 Hamburg

clas ohlson